

Long Term Maintenance Free Lubrication Unit MX Characteristics and Features

Features of Lubrication Unit MX

- **Extended maintenance period**
Long durability of lubrication performance has resulted in significant reduction of maintenance load especially with machines and equipment environments where applying grease is not easy.
- **Environmentally friendly system**
Proper amount of lubricant to ball rolling surface at right time makes the system environment-friendly.
- **Cost advantage**
Contributes to reduction of maintenance costs and product troubles caused by failing to lubricate.
- **Reduced manufacturing steps**
No need to fill with grease prior to use because the product is already filled with Lithium soap-based grease in addition to the built-in lubrication unit.

Structure of Lubrication Unit MX

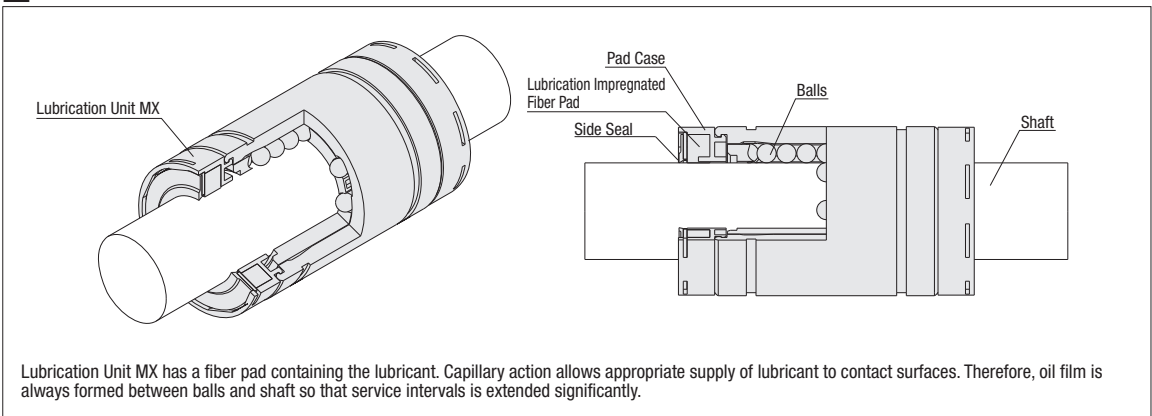

2.5x durability with a little cost addition to the Standard Type

Endurance Test Result

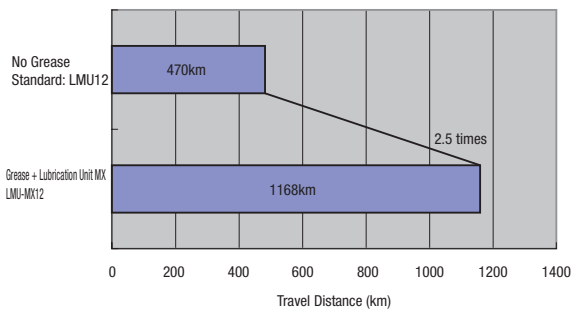

<Test Condition>

Sample : Linear Bushing LMU12 with Anti-rust oil,
Linear Bushing with Lubrication Unit LMU-MX12
Applied Load : 206N (50% against Basic Dynamic Load Rating 412N)
Average Speed : 42m/min(0.7m/sec)
Stroke : 100mm
Lubricant : Grease, initial filling only (LMU-MX12 only)
Shaft Material : EN 1.3505 Equiv. 58HRC
24 hours, continuously operated

With 50% of basic load rating applied for testing, the Lubrication Unit MX Type has shown a 2.5 times higher durability performance compared to the one without the MX lubrication unit.

*The data above are for reference only, and not guaranteed by the manufacturer.

The data was revised to the above since the 2007 catalog after the safety margin was confirmed by increased test data points.

Handling Cautions

